



I Application

The C-TOP+ control unit with AS-i (Actuator Sensor Interface) communication is designed or intended for the optimal automation of INOXPA process valves. This option is available for the entire range of valves supplied with C-TOP+ units (ball valve, butterfly valve, single and double seat multiway valve, etc.).

I Principle of operation

The AS-i interface is a field bus system that allows connecting a network of actuators and sensors (detectors) to a higher level control device (master).

An AS-i network comprises the following elements:

A power supply, one or several master (or control) modules, bus cable (preformed cable), an IDC connector, an IDC connector to C-TOP+ connector connection cable, and the C-TOP+ prepared for AS-i (special card for AS-i with connector).

The AS-i field bus obtains the required voltage from a power supply. The sensors and solenoid valves connected to the field bus are controlled by the master module.

Every master sends the information to the PLC and is able to control up to 62 slave units (62 C-TOP+ AS-i units).

The interconnection is made with a preformed cable. The preformed cable is used both for the transmission of information and as a power supply for the solenoid valves and sensors. The C-TOP AS-i head must always be used in conjunction with magneto-resistive sensors.

The C-TOP+ AS-i also incorporates three signalling LEDs which continuously indicate the status of the valve, and one flashing red LED to alert in case of signal loss.

Signal status LED			Detector signal	Status of the inputs			
Red ¹⁾	Green	Yellow		DI1	DI2	DI3	DI4
○	○	○	-	0	0	0	0
●	○	○	Detector 1 (S1)	1	0	0	0
○	●	○	Detector 2 (S2)	0	1	0	0
○	○	●	Detector 3 (S3)	0	0	1	0
○	●	●	Detector 4 (S4, external)	0	0	0	1
●	●	●	S1 and S4 (external)	1	0	0	1
○	●	●	S2 and S4 (external)	0	1	0	1
○	●	●	S3 and S4 (external)	0	0	1	1
Flashing	○	○	Signal patterns not mentioned above				

1) The red LED starts flashing after a delay of 10 seconds in patterns of DI1... DI4 not mentioned above and is permanently switched on when actuating more than one output.

I Design and features

The C-TOP+ AS-i is characterised by its modular simple and robust design which guarantees maximum flexibility during installation. Due to its enormously reduced wiring requirements, it facilitates the installation and commissioning of the system. Moreover, it reduces the commissioning time and potential installation errors.

Depending on the version, the head can have up to three solenoid valves 3/2 (NC) and three sensors. If necessary, an additional external sensor can be connected. The sensors are magnetoresistive, with contactless activation by means of a magnet connected to the control shaft. The C-TOP+ AS-i heads are configured according to each customer's requirements.

Configuration of solenoid valves

- Single-acting actuation - 1 solenoid valve
- Double-acting actuation - 2 solenoid valves
- Mixproof valve - 3 solenoid valves

Configuration of sensors

- 1 position (closed or open valve) - 1 sensor
- 2 positions (closed and open valve) - 2 sensors
- 3 positions (closed valve, open valve, Mixproof seat cleaning) - 3 sensors

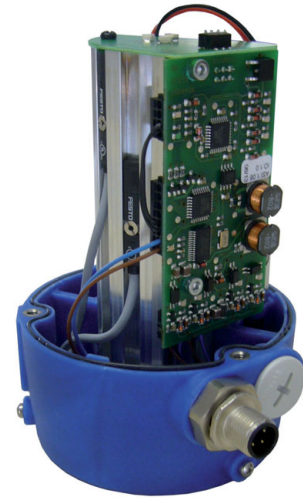

I Technical specifications

Outdoor use	C1 - protected areas
Stroke	≤ 70 mm
Maximum shaft diameter	22 mm
Mounting position	360°
Fastening type	Screws
Operating medium	Filtered compressed air, grade of filtration 40 µm, lubricated or non-lubricated
Measuring principle	Magnetoresistive (inductive), PNP, NO
Measurement parameter	Position
Visual indicators	LED
Solenoid valves	3/2 way, NC
Operating pressure	3 ... 8 bar
Nominal operating pressure	6 bar
Standard nominal flow rate	200 l/min
Storage temperature	-20 ... 60 °C
Ambient temperature	- 5... 50 °C
Protection class	IP65, IP67 (mounted head)
Protection against reverse polarization	Yes
Supply voltage	26.5 ... 31.6 VDC (via the bus line. Bus cable not included)
Max. current consumption	200mA
Pneumatic connections	
Connection 1: compressed air connection for	QS-8 operating pressure (Ø8 mm pipe)
Connection 3: exhaust	Integrated silencer
Connection A1 ... A3: working lines of the solenoid valves	QS-6 (for Ø6 mm pipe)

Profile (factory setting slave 0 address):

- S-7.A.7.7 V3.0 (slave A/B, max. 62 slave addresses)
- S-7.F.F.E V2.0 (max. 31 slave addresses) - on request



I Electrical connections

Male connector M12 x 4 poles

- 1 + AS Interface
- 2 n.c. = free (do not connect)
- 3 - AS Interface
- 4 n.c. = free (do not connect)

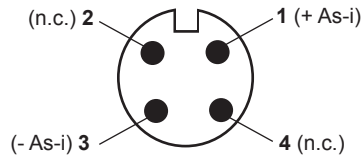

Additional connector for the fourth external detector (S4), female connector M12 x 5 poles
(Only available with 3 detectors and 3 solenoid valves)

- 1 24V (external detector S4)
- 2 n.c. = free (do not connect)
- 3 0V (external detector S4)
- 4 Detector signal (external detector S4)
- 5 n.c. = free (do not connect)

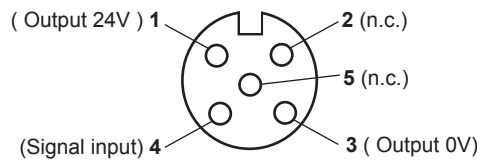

I Materials

- End cap Polypropylene
- Housing Reinforced polypropylene
- Base Reinforced polypropylene
- Seals EPDM
- Screws Stainless steel

I General dimensions

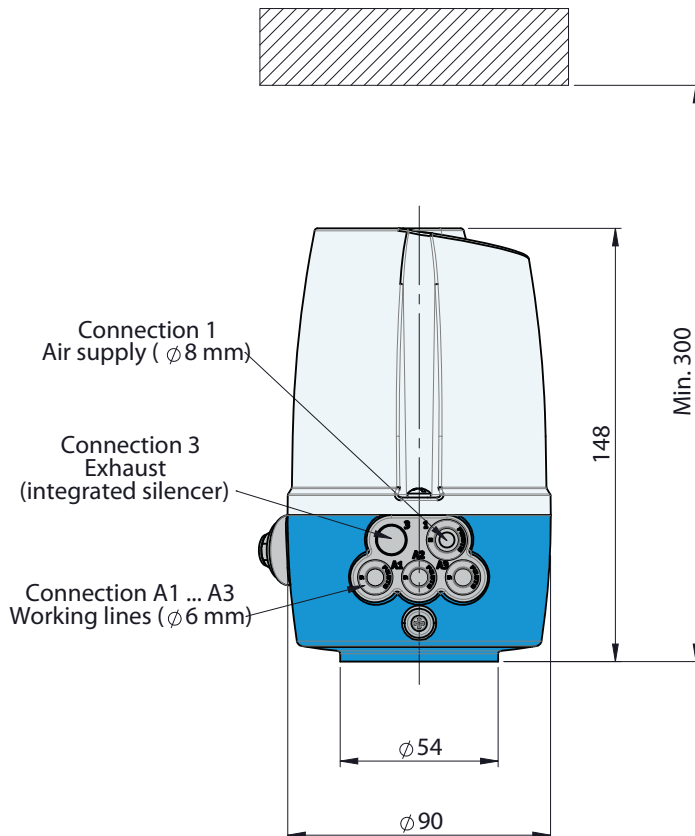
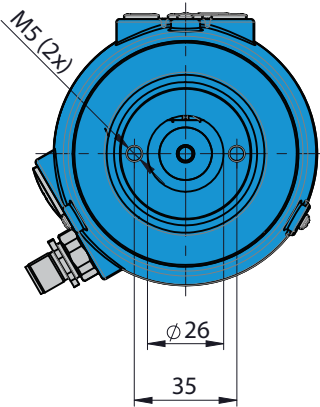

FT-C-TOP+ AS-i.1.EN-0414